

Duration: 3hrs

[Max Marks:80]

- N.B. : (1) Question No 1 is Compulsory.
 (2) Attempt any three questions out of the remaining five.
 (3) All questions carry equal marks.
 (4) Assume suitable data, if required and state it clearly.

- 1 Attempt any FOUR [20]
 a) Explain the operation of a semiconductor PN junction diode with the help of VI characteristics. [5]
 b) Explain differences between BJT and FET. [5]
 c) Explain in brief application Zener Diode as a voltage regulator. [5]
 d) State Miller's Theorem. Evaluate it for either resistive or capacitive feedback elements. [5]
 e) What is crossover distortion in a Class B Power Amplifier? How can it be avoided? [5]
- 2 a) Draw a small signal equivalent circuit for the circuit given below and derive the expression for its input impedance Z_i , output impedance Z_o and Voltage Gain A_v . [10]

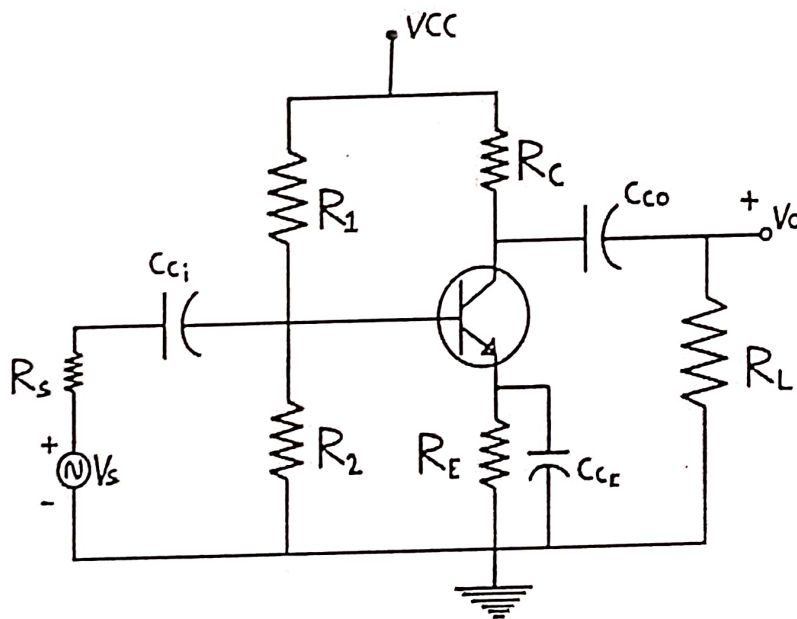

- b) Draw and explain high frequency model for BJT in CE configuration. [10]

- 3 a) Find the magnitude values of input impedance Z_i , output impedance Z_o and [10]
Voltage Gain A_v .

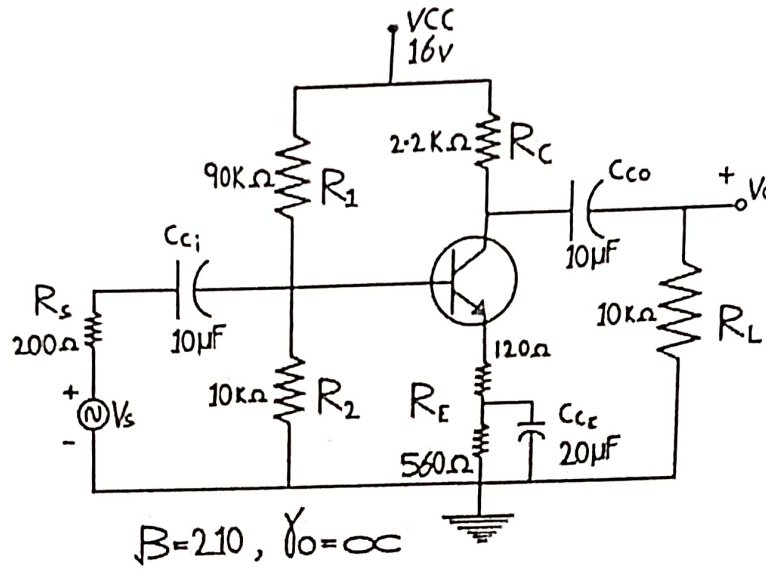

- b) Explain the operation of a MOS differential amplifier with differential mode [10]
input signal.
- 4 a) Determine I_{DQ} , V_{GSQ} and V_{DSQ} for the given circuit. [10]

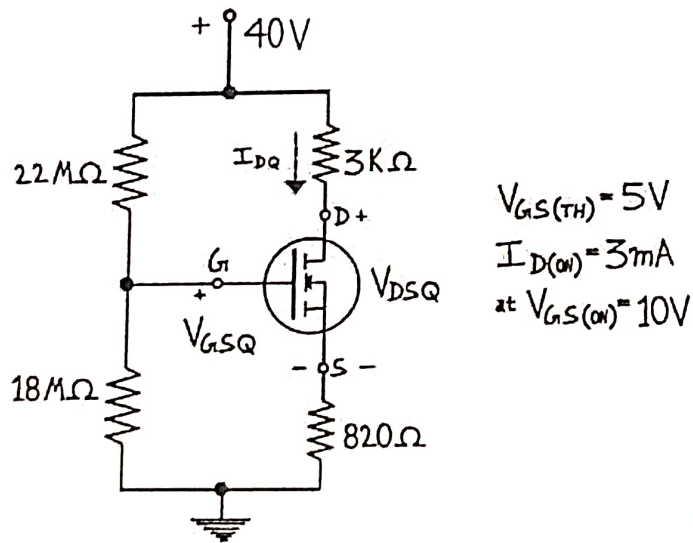

- b) Draw and explain a transformer coupled class A power amplifier with the [10]
help of neat diagram and waveforms and also derive the expression for its
power efficiency.

- 5 a) Design the following voltage divider biasing circuit for its resistance values, [10]
 if operating point Q is ($V_{CEQ} = 12V$; $I_{CQ} = 2mA$), $\beta = 100$, $V_{CC} = 20V$.
 Assume suitable data if necessary and mention your assumption.

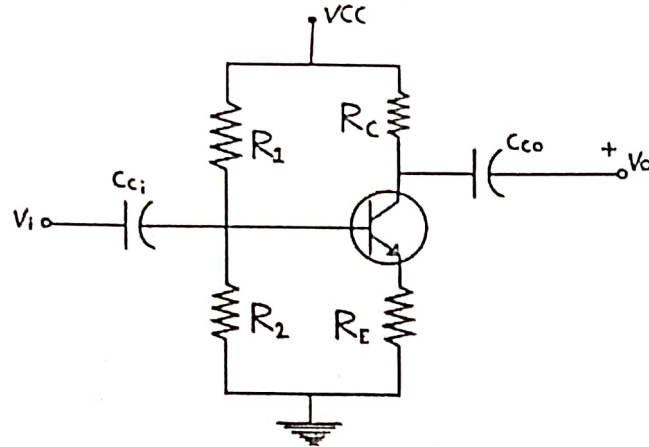

- b) Draw a frequency response plot for C_E amplifier employing potential divider bias and R_E completely bypassed. Also derive the expression for f_H for the same. [10]
- 6 Attempt any FOUR. [20]
- a) Draw and explain operation of Depletion type MOSFET. [5]
- b) Draw and explain working of a two transistor constant current source using E-MOSFET. [5]
- c) Give classification of power amplifiers and compare them. [5]
- d) Why should R_C be as large as possible in the design of C_E amplifier? [5]
- e) Draw drain and transfer characteristics for JFET and thus explain the device parameters. [5]
